

POWER STEERING

STEERING REALIABILITY SINCE 1916



Saura Keiki Seisakusho Co., Ltd., ever since established in 1916, has always been a leading manufacturer of navigational instruments and steering control system for coastal vessels.

Continual improvements in design through long experience and engineering technology in the field make SAURA Hydraulic Steering Gears one of the most reliable systems.

Principle of operation

Pump unit driven off by main engine or AC motor produces pressured hydraulic flow for fast and accurate power assisted steering.

Rotation on the steering wheel directs oil flow into either the port or starboard side of the cylinder, and then the rudder is rotated by means of the tiller.

Not like a common helm pump used in conventional type of steering system, our helm pump is so unique and it takes power assisted oil from pump unit and therefore the steering wheel is surprisingly light and easy to turn almost similar to that of power assisted steering wheel of luxury cars, with sharp and positive rudder responses.

Power Assisted Steering Gear

Pump unit is driven off by ship's main engine PTO shaft via pulley and V belt link.

It does not require electric power source to drive the hydraulic system, thus, it provides power assisted steering system most economically and simply.

Electro-Hydraulic Steering Gear

Pump unit directly connected to an electric motor delivers a constant flow of hydraulic fluid at all times.

It is our standard pump driving method for steering system of which rudder torque requirement is greater than 10 kN-m such as CD range.

An autopilot control can easily be integrated to our power assisted hydraulic steering system, by just teeing in solenoid valve unit.

Hydraulic steering system layout

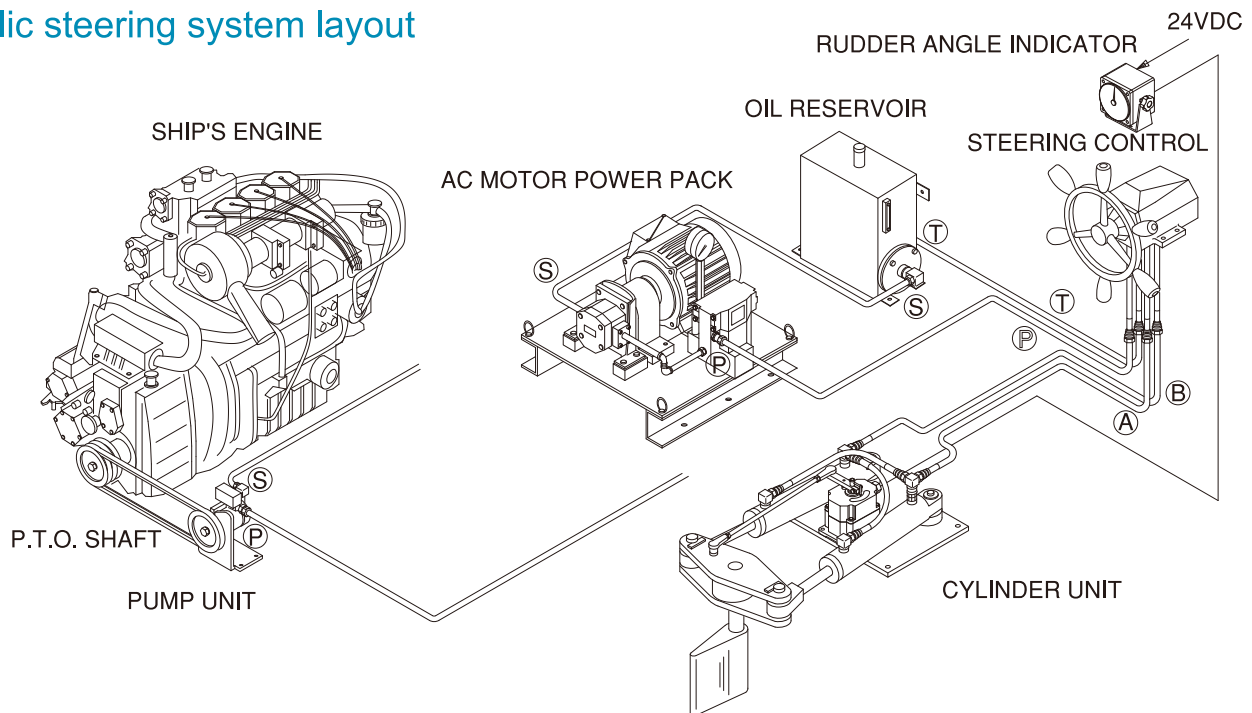

Rudder torque selection

SBO series: 1.3 ~ 8.4 kN-m (135 ~ 860 Kg-m)

CD series: 9.8 ~ 29.4 kN-m (1000 ~ 3000 Kg-m)

Ordering code : SBO series

SBO-B-8W-AE

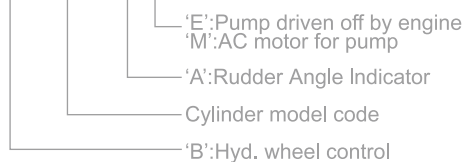

Ordering code : CD series

CD8-15-M-B-A

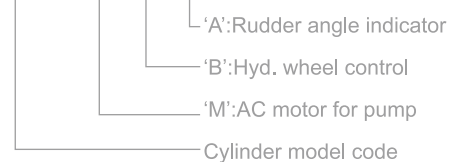

Steering Controls

Wheel Control

Steering response is sharp and powerful.

Steering wheel control is completely power assisted by the pressurized hydraulic fluid and requires little labour and force of a helmsman to turn the steering wheel.

Our steering wheel operated helm pump features an automatic, immediate change over to manual steering in absence of power assistance due to main pump failure or loss of electric supply for AC motor.

Thus, the steering wheel provides an secondary means of steering in an emergency situation.

Table top type



- Special vinyl coating on the aluminum wheel surface for prevention of rusts and corrosion.
- Horizontal grip is provided for positive and faster wheel operation.

Bulk head type



- Wall mount bracket allows shapely installation in steering room.

Power Units

Pump unit is likened to a heart of human circulating system.

Our pump units have pliable and yet powerful muscle that can handle abrupt change in rotation speed and pressure fluctuation.

Pump Unit (engine driven)



- PV-14: 9 ltr/min
- PV-17: 12 or 17 ltr/min

AC Motor Power Pack

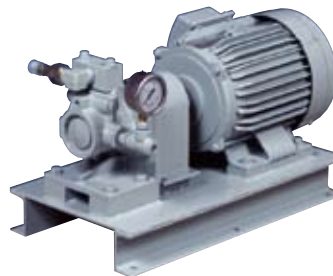

- Hydraulic pump directly coupled to an electric motor is mounted on a base plate
- Pressure gauge on request

Oil Reservoir

Management of oil is important for hydraulic steering system.

Ample oil reservoir capacity is provided and minimises temperature rise.

Made of stainless steel, and thin sectional dimension facilitates installation in limited space on floor or on wall.

Tank Unit



- TU-07: 7 ltr
- TU-14: 14 ltr
- Oil filter/strainer is fitted inside as standard
- Oil gauge for ease of maintenance.

Tank Unit with Solenoid



- TU-07S/TU-14S: come with Solenoid valve (1/4" type, 24VDC) and are used for auto pilot installation
- TU-07SF/TU-14SF: are fitted with flow control valve, enabling adjustment of rudder turning speed for optimal rudder response.

SBO series

Actuators

Our cylinder units have everything that is required of a professional and reliable steering system - durable, powerful and compact, and deliver steering command correctly to the rudder. All piston rods are chrome plated for prevention of scratches and corrosion damages. Moving parts are made of stainless steel for non-rust operation and for robustness. A wide variety of cylinder strokes and bore size selection available in single and twin ram types, to cater for rudder torque requirements.

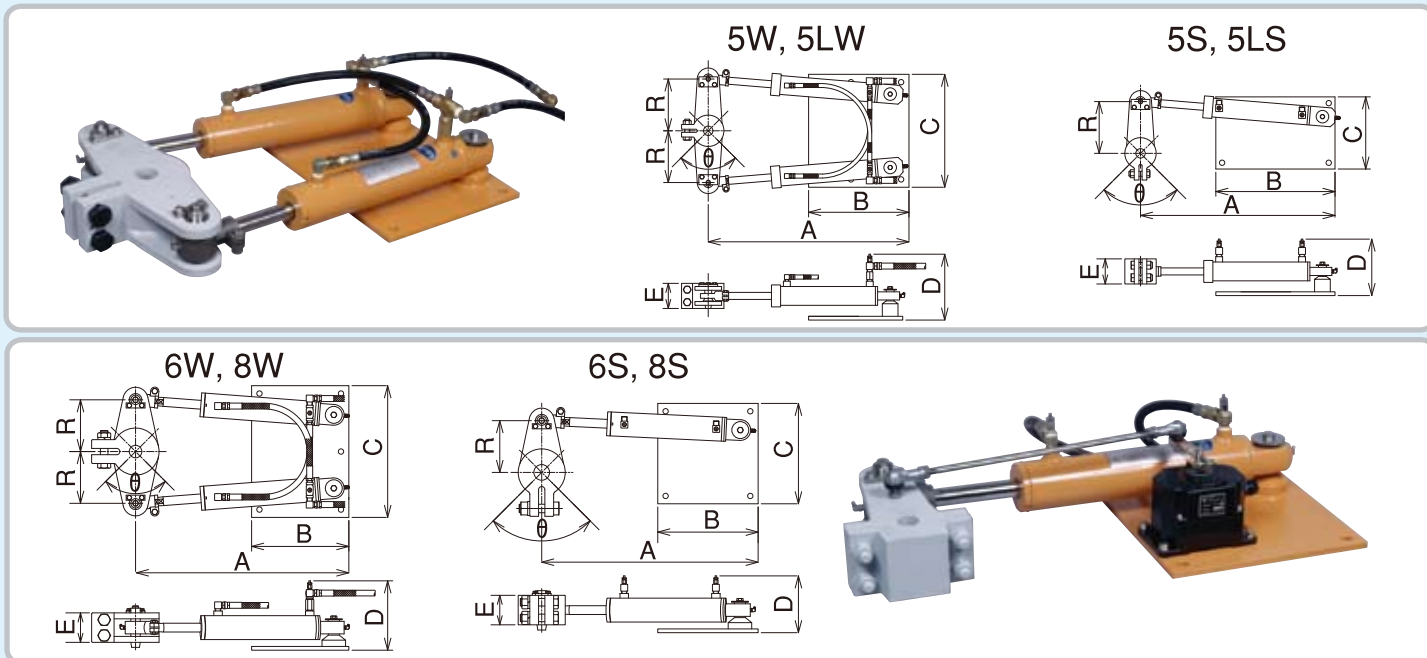

PHYSICAL DIMENSION: SBO series

	5S	5LS	6S	8S	5W	5LW	6W	8W
A	565	620	690	690	583	640	680	680
B	380	380	320	320	320	320	310	310
C	200	230	320	320	320	360	420	420
D	180	180	190	200	210	210	230	240
E	80	80	94	94	80	80	94	94
R	135	165	165	165	135	165	165	165
θ	90°	90°	90°	90°	90°	90°	90°	90°

STANDARD SPECIFICATIONS: SBO series

	Unit	5S	5W	5LS	5LW	6S	6W	8S	8W	
Rudder torque	kN-m	1.3	2.6	1.7	3.3	2.6	5.3	4.2	8.4	
Pressure ratings	MPa/70deg	6.9	6.9	6.9	6.9	6.9	6.9	6.9	6.9	
# of Wheel turns	90 deg/rev	4.5 or 5.5	7	4 or 5	9	6 or 7.5	11	8 or 10	12.5	
Helm pump (Orbitrol)		UB	UC	UC	UC	UC	UD	UD	UE	
Orbitrol displacement	cc/rev	69	96	96	96	96	120	120	159	
Cylinder bore	mm	50	50	50	50	63	63	80	80	
Cylinder stroke	mm	195	195	235	235	235	235	235	235	
Tiller radius	mm	135	135	165	165	165	165	165	165	
Rudder turning speed(90 deg)	sec	7	8	8	8	8	10	10	10	
Cylinder displacement	cc/90 deg	343	686	420	840	653	1306	1050	2100	
Qty of cylinder	piece	1	2	1	2	1	2	1	2	
Pump displacement	ltr/min	9	9	9	9	9	12	12	17	
Oil tank capacity	ltr	7	7	7	7	7	14	14	14	
Pulley dia	B1, inch	6"	6"	6"	6"	6"	6"	6"	6"	
Piping recommended	copper	ø12mm × 1.5 t (not supplied)					ø15 × 2.0 t (not supplied)			
Hydraulic oil recommended		ISO-VG32 (viscosity 30-35cSt) or equivalent (not supplied)								

CD series

Designed for commercial crafts of 19 - 300 gwt; fishing vessel, passenger ferry, cargo vessel, work boat and patrol boat. Stable rudder turning speed.

Power Units

AC Motor Power Pack

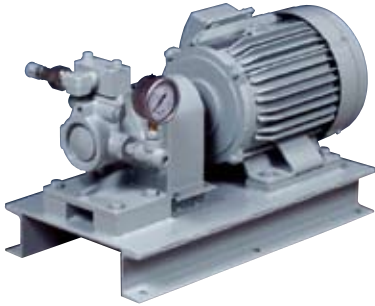

Hydraulic pump directly coupled to an electric motor is mounted on a base plate. Pressure gauge optional.

Pump Unit with Reservoir tank

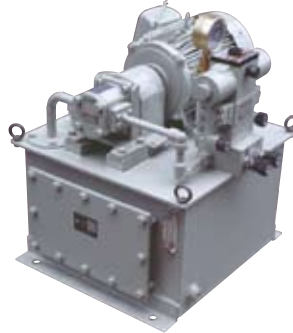

Electric motor and hydraulic pump are fitted on a 35 ltr capacity reservoir tank for minimum installation space.

AC Motor Starter



Visual and audible alarms for no-voltage and over-load conditions.

Actuators

CD series cylinder units are of clevis type, available in rudder torque range from 9.8 kN-m to 29.4 kN-m. Compact design requires minimum installation space.

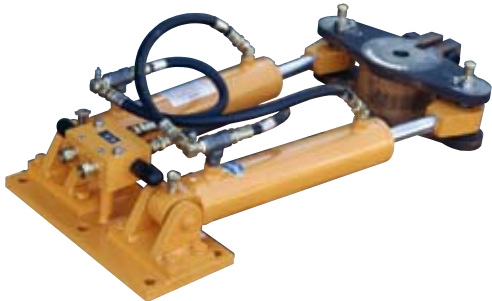

All piston rods are chrome plated for prevention of scratches and corrosion damages. Self-aligning pillow balls eliminate critical installation alignment. Bleed fittings at the cylinder ports for ease of circuit bleeding. Double acting relief valve is available on request, for added protection against excessive pressure.

STANDARD SPECIFICATIONS: CD series

	Unit	CD8-10	CD8-13	CD8-20	CD10-25	CD10-30
Rudder torque	kN-m	9.8	14.7	19.6	24.5	29.4
Pressure ratings	MPa/70deg	6.9	8	8.8	7.6	9.1
# of Wheel Turns	70 deg/rev	12.5	16	16	-	-
Helm pump (Orbitrol)		UE	UE	UG	-	-
Orbitrol displacement	cc/rev	159	159	195	-	-
Cylinder bore	mm	80	80	80	100	100
Piston rod dia.	mm	35.5	35.5	35.5	56	56
Cylinder stroke	mm	235	311	370	370	370
Tiller radius	mm	190	250	300	300	300
Rudder turning speed (70 deg)	sec	10	12	15	15	15
Cylinder displacement	cc/70 deg	1962	2581	3097	4543	4543
Qty of cylinder	piece	2	2	2	2	2
Pump displacement	ltr/min	17	17	17	20	20
Pipings recommended	steel pipe	3/8B or 1/2B SCH #80 or equivalent (not supplied)				
Hydraulic oil recommended		ISO-VG32 (viscosity 30-35cSt) or equivalent (not supplied)				

PHYSICAL DIMENSION: CD series

	CD8-10	CD8-15	CD8-20	CD10-25	CD10-30
A	565	620	690	690	583
B	380	380	320	320	320
C	200	230	320	320	320
D	180	180	190	200	210
E	80	80	94	94	80
R	135	165	165	165	135
θ	90°	90°	90°	90°	90°

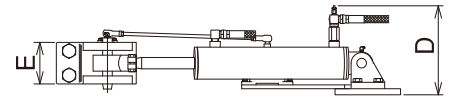
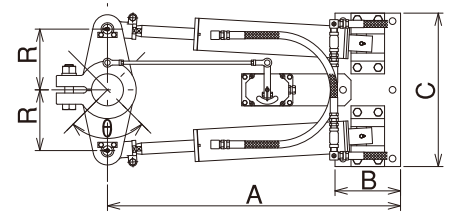
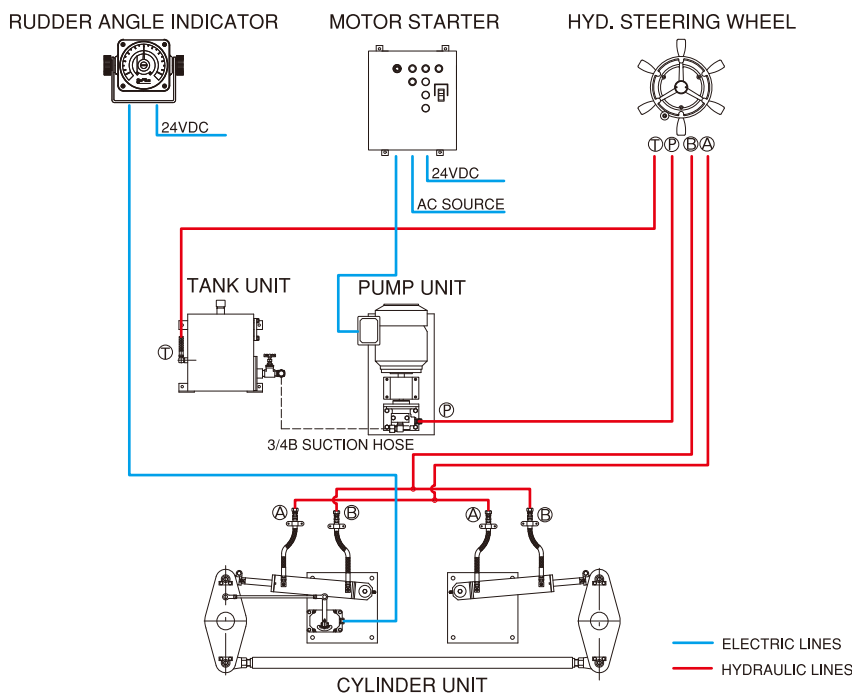
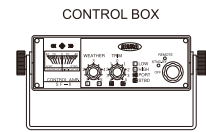

Diagram of Power assisted steering system



Electric Steering Control

Full Follow-Up



SF-8

ELECTRIC WHEEL

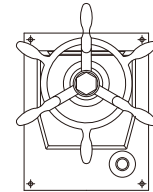

FH-5

SOLENOID VALVE

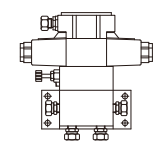

Helm Indication



TR-2

Rudder Feedback

Oil filled potentiometer for extremely long duty life.
Inner reduction gear mechanism for precise rudder position tracking.
Water tight design for trouble free operation.



A-3

Rudder Angle Indicator

270 degree deflection for easy helm reading.
Scale illuminated with dimmer control.

Specifications to change without prior notice

Distributed by:

Manufactured by:

Saura Keiki Seisakusho Co., Ltd.

Steering reliability since 1916

www.saura.jp

339-1 Ohkubo-Ryoke, Sakura-ku, Saitama 338-0826, Japan

Overseas enquiries, please contact

Fax: +81 3 3256 8540 Tel: +81 3 3256 8549